



Level



Pressure



Flow



Temperature



Liquid
Analysis



Registration



Systems
Components



Services



Solutions

Technical Information

Omnigrad M TR13

Modular RTD assembly
protection tube and neck tube, flange



Application

- Universal range of application
- Measuring range: -200...600 °C (-328...1112 °F)
- Pressure range up to 100 bar (1450 psi)
- Degree of protection: up to IP 68

Head transmitters

All Endress+Hauser transmitters are available with enhanced accuracy and reliability compared to directly wired sensors. Easy customizing by choosing one of the following outputs and communication protocols:

- Analog output 4...20 mA
- HART®
- PROFIBUS® PA
- FOUNDATION Fieldbus™

Your benefits

- High flexibility based on modular assembly with standard terminal heads and customized immersion length
- Highest possible compatibility with a design according to DIN 43772
- Neck tube for heat protection of head transmitter
- Fast response time with reduced/tapered tip form
- Types of protection for use in hazardous locations:
Intrinsic Safety (Ex ia)
Non-Sparking (Ex nA)



Function and system design

Measuring principle

These resistance thermometers use a Pt100 temperature sensor according to IEC 60751. This temperature sensor is a temperature-sensitive platinum resistor with a resistance of 100 Ω at 0 °C (32 °F) and a temperature coefficient $\alpha = 0.003851 \text{ } ^\circ\text{C}^{-1}$.

There are generally two different kinds of platinum resistance thermometers:

- **Wire wound (WW):** Here, a double coil of fine, high-purity platinum wire is located in a ceramic support. This is then sealed top and bottom with a ceramic protective layer. Such resistance thermometers not only facilitate very reproducible measurements but also offer good long-term stability of the resistance/temperature characteristic within temperature ranges up to 600 °C (1112 °F). This type of sensor is relatively large in size and it is comparatively sensitive to vibrations.
- **Thin film platinum resistance thermometers (TF):** A very thin, ultrapure platinum layer, approx. 1 μm thick, is vaporized in a vacuum on a ceramic substrate and then structured photolithographically. The platinum conductor paths formed in this way create the measuring resistance. Additional covering and passivation layers are applied and reliably protect the thin platinum layer from contamination and oxidation even at high temperatures.

The primary advantages of thin-film temperature sensors over wire wound versions are their smaller sizes and better vibration resistance. A relatively low principle-based deviation of the resistance/temperature characteristic from the standard characteristic of IEC 60751 can frequently be observed among TF sensors at high temperatures. As a result, the tight limit values of tolerance category A as per IEC 60751 can only be observed with TF sensors at temperatures up to approx. 300 °C (572 °F). For this reason, thin-film sensors are generally only used for temperature measurements in ranges below 400 °C (932 °F).

Measuring system

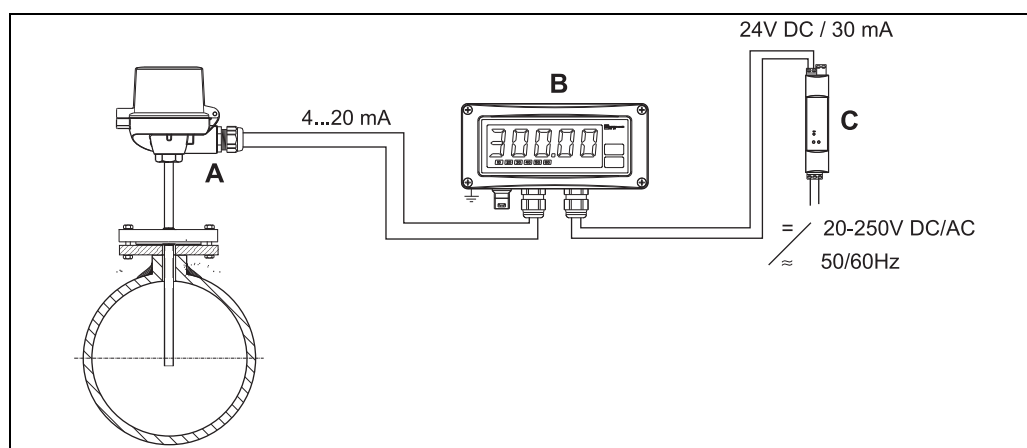

Example of an application

- A Built-in RTD assembly TR13 with head transmitter
- B RIA261 Field display
 - The display measures an analog measurement signal and indicates this on the display. The display is connected in a 4 to 20 mA current loop and also derives its supply from the loop. The voltage drop is almost negligible (< 2.5 V). The dynamic internal resistance (load) makes sure that independently from the loop current, the maximum voltage drop is never exceeded. The analog signal at the input is digitalized, analyzed and displayed. For details see Technical Information (see chapter "Documentation").
- C Active barrier RN221N
 - The RN221N active barrier (24 V DC, 30 mA) has a galvanically isolated output for supplying voltage to loop powered transmitters. The power supply has a wide-range input for mains power, 20 to 250 V DC/AC, 50/60 Hz to be used in any electrical circuit. For details see Technical Information (see chapter "Documentation").

Equipment architecture

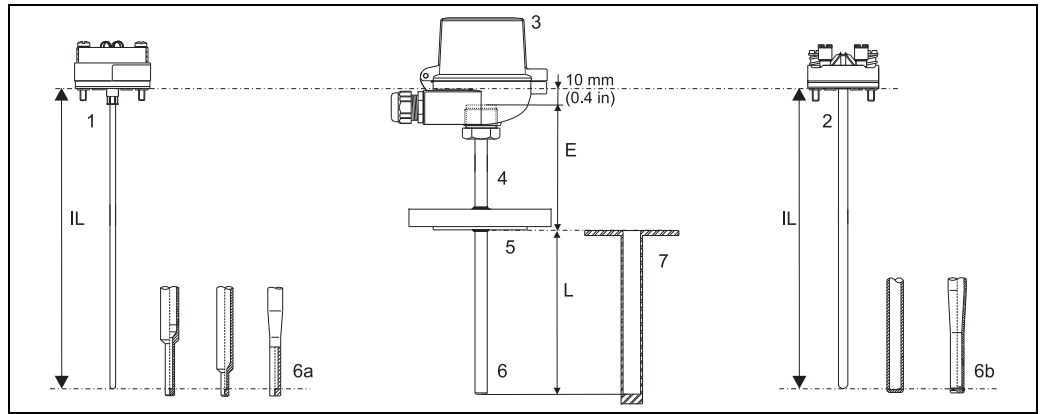

Equipment architecture of the Omnigrad M TR13

- | | | | |
|---|--|----|--|
| 1 | Insert (\varnothing 3 mm, 0.12 in) with mounted head transmitter, for example | 6 | Various tip shapes – detailed information see chapter 'tip shape': |
| 2 | Insert (\varnothing 6 mm, 0.24 in) with mounted ceramic terminal block, for example | 6a | Reduced or tapered for inserts with \varnothing 3 mm (0.12 in) |
| 3 | Terminal head | 6b | Straight or tapered for inserts with \varnothing 6 mm (0.24 in) |
| 4 | Protection armature | 7 | Jacket (protective sheath) |
| 5 | Flange as process connection | E | Neck tube length |
| | | L | Immersion length |
| | | IL | Insertion length = $E + L + 10$ mm (0.4 in) |

The Omnigrad M TR13 RTD assemblies are modular. The terminal head serves as a connection module for the protection armature in the process as well as for the mechanical and electrical connection of the measuring insert. The actual RTD sensor element is fitted in and mechanically protected within the insert. The insert can be exchanged and calibrated even during the process. Either ceramic terminal blocks or transmitters can be fitted to the internal base washer. The protection tube is with a diameter of 9, 11 or 12 mm (0.35, 0.43 or 0.47 in). The tip shape can be straight, tapered (i.e. with a gradual reduction of the stem achieved thanks to a swaging procedure), or reduced (stepped). A jacket in plastic may be fitted on protection tubes with straight tip. The assemblies can be fitted onto a tube or tank using a flanged process connection, which can be chosen from the most common models (see chapter 'process connection', → 14).

Measurement range

-200...+600 °C (-328...+1112 °F)

Performance characteristics

Operating conditions

Ambient temperature

Terminal head	Temperature in °C (°F)
Without mounted head transmitter	Depends on the terminal head used and the cable gland or fieldbus connector, see 'Terminal heads' section, → 10
With mounted head transmitter	-40 to 85 °C (-40 to 185 °F)
With mounted head transmitter and display	-20 to 70 °C (-4 to 158 °F)

Process pressure

The pressure values to which the protection tube can be subjected at the various temperatures and maximum permitted flow velocity are illustrated by the figure below. Occasionally, the pressure loading capacity of the process connection can be considerably lower. The maximum allowable process pressure for a specific thermometer is derived from the lower pressure value of the thermowell and process connection.

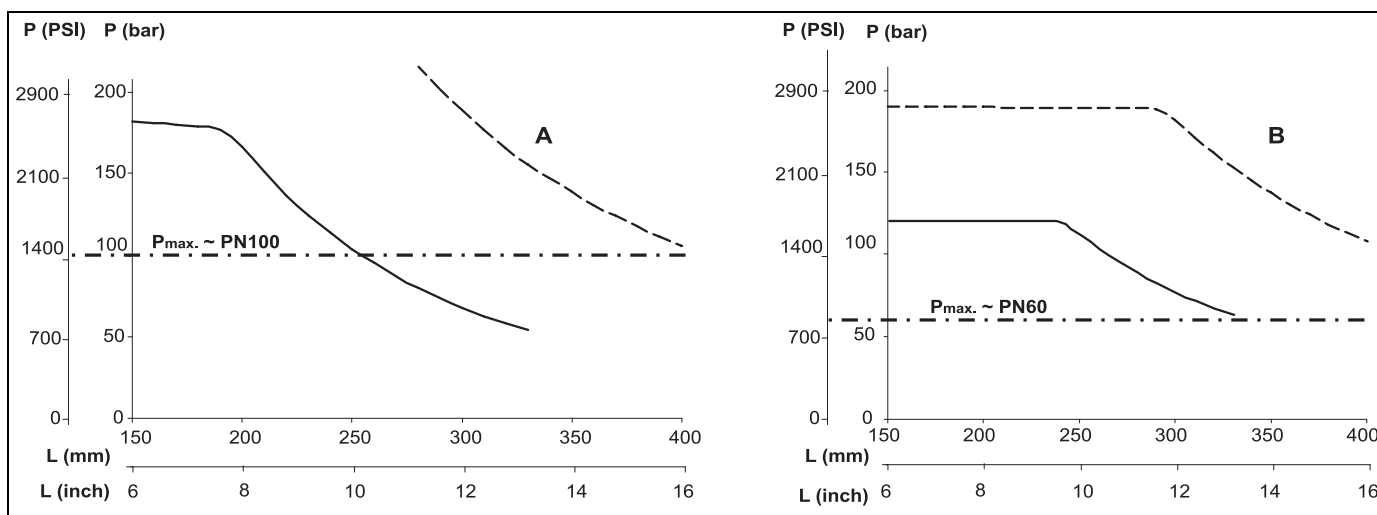

Maximum permitted process pressure for tube diameter
 – Protection tube diameter 9 x 1 mm (0.35 in) ———
 – Protection tube diameter 12 x 2.5 mm (0.47 in) - - - - -

A Medium water at T = 50 °C (122 °F)

B Medium superheated steam at T = 400 °C (752 °F)

L Immersion length

P Process pressure



Note!

Note the limitation of the maximum process pressure to the flange pressure ratings indicated in the following table.

Process connection	Standard	max. process pressure
Flange	EN1092-1 or ISO 7005-1	Depending on the flange pressure rating PNxx: 20, 40, 50 or 100 bar at 20 °C (68 °F)
Flange	ASME B16.5	Depending on the flange pressure rating 150 or 300 psi at 20 °C (68 °F)

The pressure loading capacity of the flanges depends on the process temperature. More detailed information on this is provided in the corresponding standard and in the 'Flanges' Technical Information, TI432F/00.

Maximum flow velocity

The highest flow velocity tolerated by the protection tube diminishes with increasing immersion length exposed to the stream of the fluid. Detailed information may be taken from the figures below.

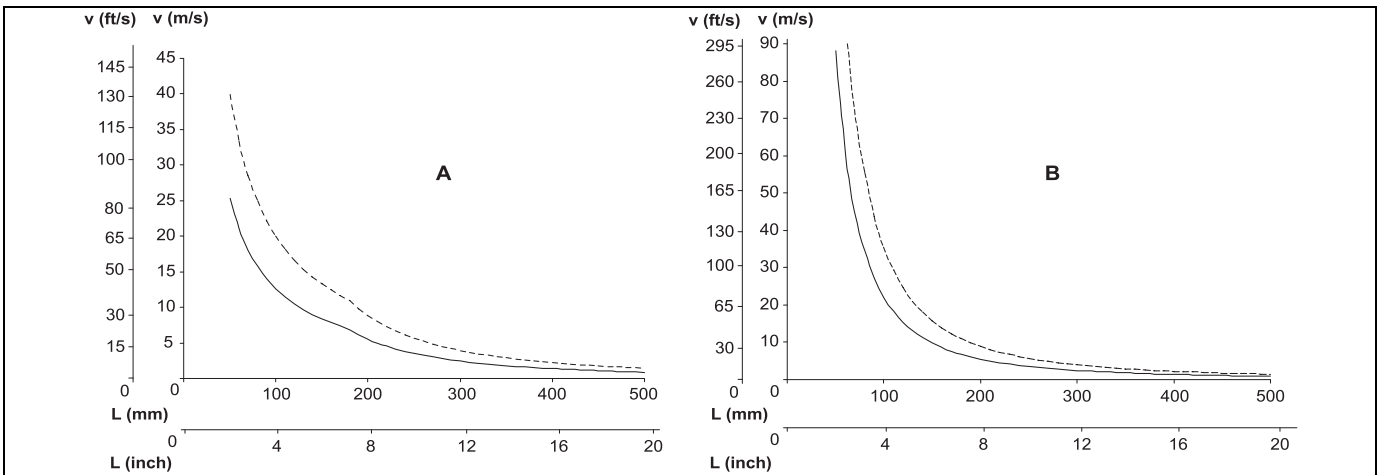

Flow velocity depending on the immersion length
 – Protection tube diameter 9 x 1 mm (0.35 in) ———
 – Protection tube diameter 12 x 2.5 mm (0.47 in) - - - - -

- | | | | |
|---|---|---|------------------|
| A | Medium water at T = 50 °C (122 °F) | L | Immersion length |
| B | Medium superheated steam at T = 400 °C (752 °F) | v | Flow velocity |

Shock and vibration resistance

3g / 10 to 500 Hz as per IEC 60751 (RTD-Thermometer)

Accuracy

RTD corresponding to IEC 60751

Class	max. Tolerances (°C)	Temperature range	Characteristics
RTD max. error type TF - range: -50 to +400 °C			
Cl. A	$\pm (0.15 + 0.002 \cdot t ^{1.1})$	-50 °C to +250 °C	
Cl. AA, former 1/3 Cl. B	$\pm (0.1 + 0.0017 \cdot t ^{1.1})$	0 °C to +150 °C	
Cl. B	$\pm (0.3 + 0.005 \cdot t ^{1.1})$	-50 °C to +400 °C	
RTD max. error type WW - range: -200 to +600 °C			
Cl. A	$\pm (0.15 + 0.002 \cdot t ^{1.1})$	-200 °C to +600 °C	
Cl. AA, former 1/3 Cl. B	$\pm (0.1 + 0.0017 \cdot t ^{1.1})$	0 °C to +250 °C	
Cl. B	$\pm (0.3 + 0.005 \cdot t ^{1.1})$	-200 °C to +600 °C	

1) $|t|$ = absolute value °C

Note!

For measurement errors in °F, calculate using equations above in °C, then multiply the outcome by 1.8.

Response time

Tests in water at 0.4 m/s (1.3 ft/s), according to IEC 60751; 10 K temperature step change. Measuring probe Pt100, TF/WW:

Protection tube				
Diameter	Response time	Reduced tip Ø 5.3 mm (0.2 in)	Tapered tip Ø 6.6 mm (0.26 in) or Ø 9 mm (0.35 in)	Straight tip
9 x 1 mm (0.35 in)	t_{50} t_{90}	7.5 s 21 s	11 s 37 s	18 s 55 s
11 x 2 mm (0.43 in)	t_{50} t_{90}	7.5 s 21 s	not available not available	18 s 55 s
12 x 2.5 mm (0.47 in)	t_{50} t_{90}	not available not available	11 s 37 s	38 s 125 s



Note!

Response time for the sensor assembly without transmitter.

Insulation resistance

Insulation resistance $\geq 100 \text{ M}\Omega$ at ambient temperature.

Insulation resistance between each terminal and the sheath is measured with a voltage of 100 V DC.

Self heating

RTD elements are passive resistances that are measured using an external current. This measurement current causes a self heating in the RTD element itself which in turn creates an additional measurement error. In addition to the measurement current the size of the measurement error is also affected by the temperature conductivity and flow velocity of the process. This self heating error is negligible when an Endress+Hauser iTEMP® temperature transmitter (very small measurement current) is connected.

Calibration specifications

Endress+Hauser provides comparison temperature calibration from -80 to +600 °C (-110 °F to 1112 °F) based on the International Temperature Scale (ITS90). Calibrations are traceable to national and international standards. The calibration report is referenced to the serial number of the thermometer. Only the measurement insert is calibrated.

Insert-Ø: 6 mm (0.24 in) and 3 mm (0.12 in)	Minimum insertion length IL in mm (in)	
	without head transmitter	with head transmitter
-80 °C to -40 °C (-110 °F to -40 °F)	200 (7.87)	
-40 °C to 0 °C (-40 °F to 32 °F)	160 (6.3)	
0 °C to 250 °C (32 °F to 480 °F)	120 (4.72)	150 (5.9)
250 °C to 550 °C (480 °F to 1020 °F)	300 (11.81)	
550 °C to 650 °C (1020 °F to 1202 °F)	400 (15.75)	

Material

Extension neck, protection tube and measuring insert

The temperatures for continuous operation specified in the following table are only intended as reference values for use of the various materials in air and without any significant compressive load. The maximum operation temperatures are reduced considerably in some cases where abnormal conditions such as high mechanical load occur or in aggressive media.

Material	Short description	max. application temperature	Characteristics
Wetted parts			
AISI 316L/ 1.4404 1.4435	X2CrNiMo17-12-2 X2CrNiMo18-14-3	650 °C (1200 °F) ¹⁾	<ul style="list-style-type: none"> ■ Austenitic, stainless steel ■ High corrosion resistance in general ■ Particularly high corrosion resistance in chlorine-based and acidic, non-oxidizing atmospheres through the addition of molybdenum (e.g. phosphoric and sulfuric acids, acetic and tartaric acids with a low concentration) ■ Increased resistance to intergranular corrosion and pitting ■ Compared to 1.4404, 1.4435 has even higher corrosion resistance and a lower delta ferrite content
AISI 316Ti/ 1.4571	X6CrNiMoTi17-12-2	700 °C (1292 °F) ¹⁾	<ul style="list-style-type: none"> ■ Properties comparable to AISI316L ■ Addition of titanium means increased resistance to intergranular corrosion even after welding ■ Broad range of uses in the chemical, petrochemical and oil industries as well as in coal chemistry ■ Can only be polished to a limited extent, titanium streaks can form
Hastelloy® C276/2.4819	NiMo 16 Cr 15 W	1100 °C (2012 °F)	<ul style="list-style-type: none"> ■ A nickel-based alloy with good resistance to oxidizing and reducing atmospheres, even at high temperatures ■ Particularly resistant to chlorine gas and chloride as well as to many oxidizing mineral and organic acids
Jacket			
PTFE (Teflon)	Polytetrafluorethylen	250 °C (482 °F)	<ul style="list-style-type: none"> ■ Resistant to almost all chemicals ■ High temperature stability
PVDF	Polyvinylidene fluoride	80 °C (176 °F)	<ul style="list-style-type: none"> ■ High stability ■ A high creepage stability under continuous demand ■ Good cold properties
Tantalum	-	250 °C (482 °F)	<ul style="list-style-type: none"> ■ With the exception of hydrofluoric acid, fluorine and fluorides, tantalum exhibits excellent resistance to most mineral acids and saline solutions ■ Prone to oxidation and embrittlement at higher temperatures in air

1) Can be used to a limited extent up to 800 °C (1472 °F) for low compressive loads and in non-corrosive media. Please contact your Endress+Hauser sales team for further information.

Transmitter specifications

	TMT180 PCP Pt100	TMT181 PCP Pt100, TC, Ω, mV	TMT182 HART® Pt100, TC, Ω, mV	TMT84 PA / TMT85 FF Pt100, TC, Ω, mV
Measurement accuracy	0.2 °C (0.36 °F), optional 0.1 °C (0.18 °F) or 0.08% % is related to the adjusted measurement range (the larger value applies)	0.2 °C (0.36 °F) or 0.08%		0.1 °C (0.18 °F)
Sensor current	I ≤ 0.6 mA		I ≤ 0.2 mA	I ≤ 0.3 mA
Galvanic isolation (input/output)	-		Û = 2 kV AC	

Transmitter long-term stability

≤ 0.1 °C/year (≤ 0.18 °F / year) or ≤ 0.05% / year
Data under reference conditions; % relates to the set span. The larger value applies.

Components

Family of temperature transmitters

Thermometers fitted with iTEMP® transmitters are an installation ready complete solution to improve temperature measurement by increasing accuracy and reliability, when compared to direct wired sensors, as well as reducing both wiring and maintenance costs.

PC programmable head transmitter TMT180 and TMT181

They offer a high degree of flexibility, thereby supporting universal application with low inventory storage. The iTEMP® transmitters can be configured quickly and easily at a PC. Endress+Hauser offers the ReadWin® 2000 configuration software for this purpose. This software can be downloaded free of charge at www.readwin2000.com. More information can be found in the Technical Information (see "Documentation" section).

HART® TMT182 head transmitter

HART® communication is all about easy, reliable data access and getting additional information about the measurement point more inexpensively. iTEMP® transmitters integrate seamlessly into your existing control system and provide painless access to numerous diagnostic information. Configuration with a hand-held (Field Xpert SFX100 or DXR375) or a PC with configuration program (FieldCare, ReadWin® 2000) or configure with AMS or PDM. Details see Technical Information (see chapter 'Documentation').

Type of transmitter	Specification
iTEMP® TMT18x 	<ul style="list-style-type: none"> ■ Material: Housing (PC), Potting (PUR) ■ Terminals: Cable up to max. ≤ 2.5 mm² / 16 AWG (secure screws) or with wire end ferrules ■ Eyelets for easy connection of a HART®-handheld terminal with alligator clips ■ Degree of protection NEMA 4 (see also type of terminal head) Details see Technical Information (see chapter 'Documentation')

PROFIBUS® PA TMT84 head transmitter



Universally programmable head transmitter with PROFIBUS® PA communication. Converting various input signals into a digital output signal. High accuracy over the complete ambient temperature range. Swift and easy operation, visualization and maintenance using a PC directly from the control panel, e. g. using operating software such as FieldCare, Simatic PDM or AMS.

Benefits are: dual sensor input, highest reliability in harsh industrial environments, mathematic functions, thermometer drift monitoring, sensor back-up functionality, sensor diagnosis functions and sensor-transmitter matching using Callendar-Van Dusen coefficients. Details see Technical Information (see chapter 'Documentation').

FOUNDATION Fieldbus™ TMT85 head transmitter

Universally programmable head transmitter with FOUNDATION Fieldbus™ communication. Converting various input signals into a digital output signal. High accuracy over the complete ambient temperature range. Swift and easy operation, visualization and maintenance using a PC directly from the control panel, e. g. using operating software such as ControlCare from Endress+Hauser or the NI Configurator from National Instruments.

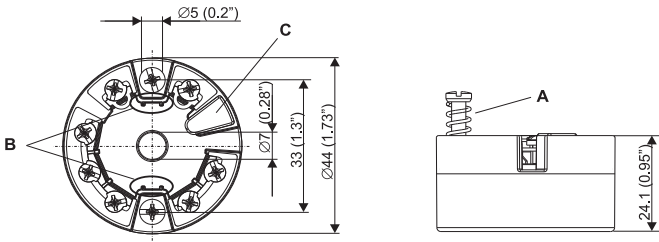
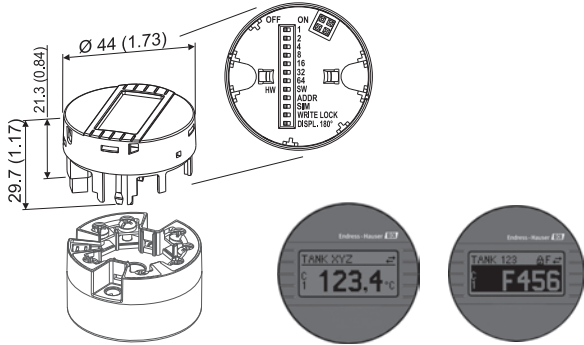
Benefits are: dual sensor input, highest reliability in harsh industrial environments, mathematic functions, thermometer drift monitoring, sensor back-up functionality, sensor diagnosis functions and sensor-transmitter matching using Callendar-Van Dusen coefficients. Details see Technical Information (see chapter 'Documentation').

Type of transmitter	Specification
<p>iTEMP® TMT84 and TMT85</p>  <p style="text-align: right; font-size: small;">a0007301-en</p>	<ul style="list-style-type: none"> ■ Spring range $L \geq 5 \text{ mm (0.2\"}$ ■ Fixing elements for pluggable measured value display, see Pos. B ■ Interface for contacting measured value display, see Pos. C ■ Material (RoHS-compliant) Housing: PC Potting: PU ■ Terminals: Screw terminals (cable up to max. $\leq 2.5 \text{ mm}^2 / 16 \text{ AWG}$) or spring terminals (e. g. from 0.25 mm^2 to $0.75 \text{ mm}^2 / 24 \text{ AWG}$ to 18 AWG for flexible wires with wire-end ferrules with plastic ferrule) ■ Degree of protection NEMA 4 (see also type of terminal head) <p>Details see Technical Information (see chapter 'Documentation')</p>
<p>Pluggable display TID10 as option</p>  <p style="text-align: right; font-size: small;">a0009955</p>	<ul style="list-style-type: none"> ■ Displays the actual measured value and the measurement point identification ■ Displays fault events in inverse color with channel ident and diagnostics code ■ DIP-switches on the rear for hardware set-up, e. g. PROFIBUS® PA bus address <p> Note! Display is only available with suitable terminal head with display window, e.g. TA30</p>

Terminal heads

All terminal heads have an internal shape and size in accordance with DIN EN 50446, flat face and a thermometer connection of M24x1.5.

All dimensions in mm (in). The cable glands in the diagrams correspond to M20x1.5 connections.

Specifications without head transmitter installed. For ambient temperatures with head transmitter installed, see 'Operating conditions' section.

TA30A	Specification
	<ul style="list-style-type: none"> ■ Degree of protection: IP66/68 ■ Max. temperature: 150 °C (300 °F) ■ Material: aluminum, polyester powder coated Seals: silicone ■ Cable entry incl. glands: ½" NPT and M20x1.5, only thread: G ½", plugs: M12x1 PA, 7/8" FF ■ Protection armature connection: M24x1.5 ■ Head color: blue RAL 5012 ■ Cap color: grey RAL 7035 ■ Weight: 330 g (11.64 oz)

TA30A with display window	Specification
	<ul style="list-style-type: none"> ■ Degree of protection: IP66/68 ■ Max. temperature: 150 °C (300 °F) ■ Material: aluminum, polyester powder coated Seals: silicone ■ Cable entry incl. glands: ½" NPT and M20x1.5, only thread: G ½", plugs: M12x1 PA, 7/8" FF ■ Protection armature connection: M24x1.5 ■ Head color: blue RAL 5012 ■ Cap color: grey RAL 7035 ■ Weight: 420 g (14.81 oz) ■ Head transmitter optional with TID10 display

TA30D	Specification
	<ul style="list-style-type: none"> ■ Degree of protection: IP66/68 ■ Max. temperature: 150 °C (300 °F) ■ Material: aluminum, polyester powder coated Seals: silicone ■ Cable entry incl. glands: ½" NPT and M20x1.5, only thread: G ½", plugs: M12x1 PA, 7/8" FF ■ Protection armature connection: M24x1.5 ■ Two head transmitters can be mounted. In the standard version, one transmitter is mounted in the terminal head cover and an additional terminal block is installed directly on the insert. ■ Head color: blue RAL 5012 ■ Cap color: grey RAL 7035 ■ Weight: 390 g (13.75 oz)

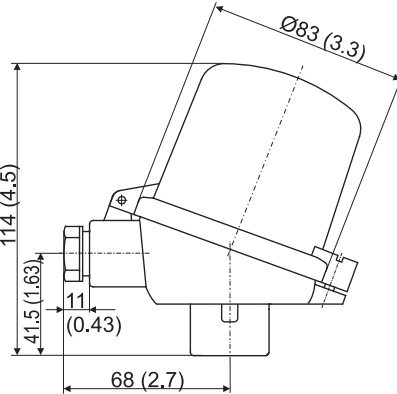
TA30P	Specification
 <p style="text-align: right; font-size: small;">a0012930</p>	<ul style="list-style-type: none"> ■ Degree of protection: IP65 ■ Max. temperature: 120 °C (248 °F) ■ Material: polyamide (PA), antistatic ■ Seals: silicone ■ Cable entry: M20x1.5 ■ Head and cap color: black ■ Weight: 135 g (4.8 oz) ■ Types of protection for use in hazardous locations: Intrinsic Safety (Ex ia)

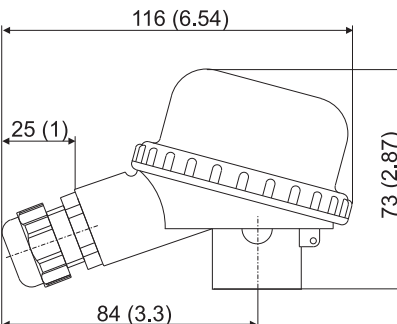
TA20B	Specification
 <p style="text-align: right; font-size: small;">a0008663</p>	<ul style="list-style-type: none"> ■ Degree of protection: IP65 ■ Max. temperature: 80 °C (176 °F) ■ Material: polyamide (PA) ■ Cable entry: M20x1.5 ■ Head and cap color: black ■ Weight: 80 g (2.82 oz) ■ 3-A[®] marked

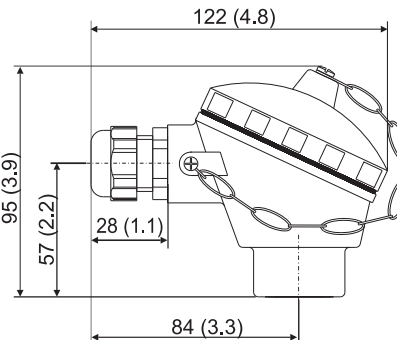
TA21E	Specification
 <p style="text-align: right; font-size: small;">a0008669</p>	<ul style="list-style-type: none"> ■ Degree of protection: IP65 ■ Max. temperature: 130 °C (266 °F) silicone, 100 °C (212 °F) rubber (observe max. permitted temperature of the cable gland!) ■ Material: aluminum alloy with polyester or epoxy coating; rubber or silicone seal under the cover ■ Cable entry: M20x1.5 or plug M12x1 PA ■ Protection armature connection: M24x1.5, G 1/2" or NPT 1/2" ■ Head color: blue RAL 5012 ■ Cap color: grey RAL 7035 ■ Weight: 300 g (10.58 oz) ■ 3-A[®] marked

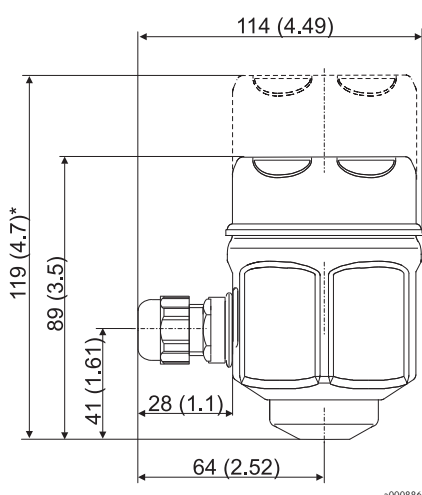
TA20J	Specification
 <p><i>* dimensions with optional display</i></p>	<ul style="list-style-type: none"> ■ Degree of protection: IP66/IP67 ■ Max. temperature: 70 °C (158 °F) ■ Material: 316L (1.4404) stainless steel, rubber seal under the cover (hygienic design) ■ 4 digits 7-segments LC display (loop powered with 4...20 mA transmitter) ■ Cable entry: ½" NPT, M20x1.5 or plug M12x1 PA ■ Protection armature connection: M24x1.5 or ½" NPT ■ Head and cap color: stainless steel, polished ■ Weight: 650 g (22.93 oz) with display ■ Humidity: 25 to 95%, no condensation ■ 3-A[®] marked <p>The programming is executed through 3 keys at the bottom of the display.</p>

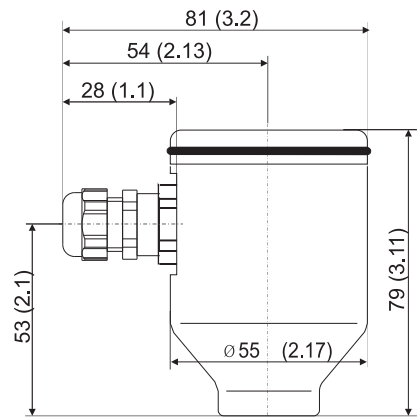
TA20R	Specification
	<ul style="list-style-type: none"> ■ Degree of protection: IP66/67 ■ Max. temperature: 100 °C (212 °F) ■ Material: SS 316L (1.4404) stainless steel ■ Cable entry: ½" NPT, M20x1.5 or plug M12x1 PA ■ Head and cap color: stainless steel ■ Weight: 550 g (19.4 oz) ■ LABS - free ■ 3-A[®] marked

Maximum ambient temperatures for cable glands and fieldbus connectors	
Type	Temperature range
Cable gland ½" NPT, M20x1.5 (non Ex)	-40 to +100 °C (-40 to +212 °F)
Cable gland M20x1.5 (for dust ignition-proof area)	-20 to +95 °C (-4 to +203 °F)
Fieldbus connector (M12x1 PA, 7/8" FF)	-40 to +105 °C (-40 to +221 °F)

Protection tube

All dimensions in mm (in).

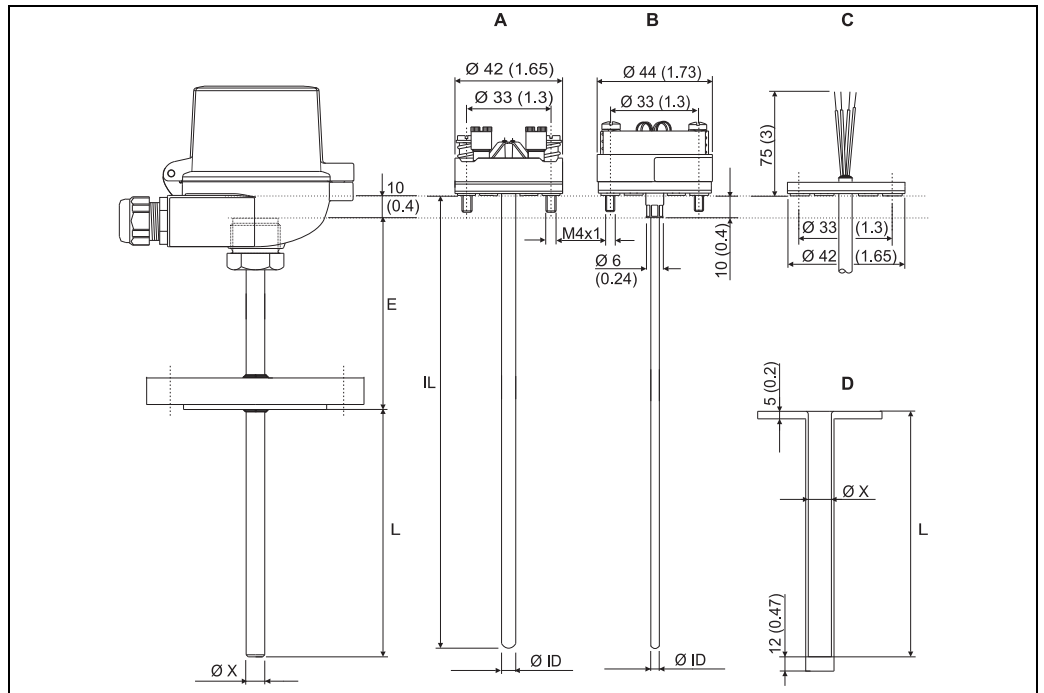

Dimensions of the Omnigrad M TR13

- A Model with terminal block mounted
- B Model with head transmitter mounted
- C Model with flying leads
- D Jacket
- E Neck tube length
- Ø ID Insert diameter
- IL Insertion length = E + L + 10 mm (0.4 in)
- L Immersion length
- Ø X Protection tube diameter

Tip shape

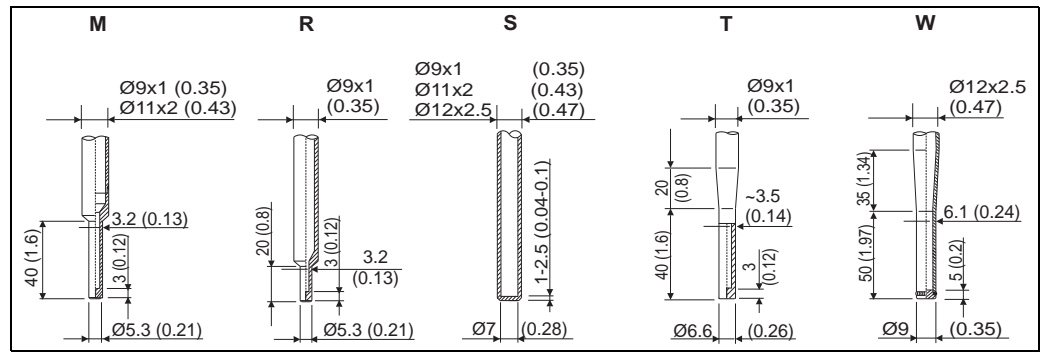

Available versions of protection tube tips (reduced, straight, tapered). Maximum surface roughness ≤ Ra 0.8 µm (31.5 µin)

Pos. No.	Tip shape, L = Immersion length	Insert Diameter
M	Reduced, L ≥ 50 mm (1.97 in)	Ø 3 mm (0.12 in)
R	Reduced, L ≥ 30 mm (1.18 in) ¹⁾	Ø 3 mm (0.12 in)
S	Straight	Ø 6 mm (0.24 in)
T	Tapered, L ≥ 70 mm (2.76 in)	Ø 3 mm (0.12 in)
W	Tapered DIN43772-3F	Ø 6 mm (0.24 in)

1) not with material Hastelloy® C276/2.4819 and not recommended for the Pt100 wire wound sensor.

Jacket

For thermowells with straight tip shape and protection tube diameter 11 and 12 mm (0.43 and 0.47 in), a jacket in PTFE (Teflon®), PVDF or Tantalum is available. The external diameter of the thermowell stem will be 15 and 16 mm (0.6 and 0.63 in), for Tantalum 12 mm (0.47 in). The immersion length L will be slightly higher also because of the different thermal expansion of the protection tube and jacket. The upper part of the jacket is fitted with a disc of the same material that is inserted between the flange and counterflange.

Weight From 1.5 to 3.5 kg (3.3 to 7.7 lbs) for standard options.

Process connection The following figure shows the basic dimensions of the available flanges (see chapter "Ordering information").

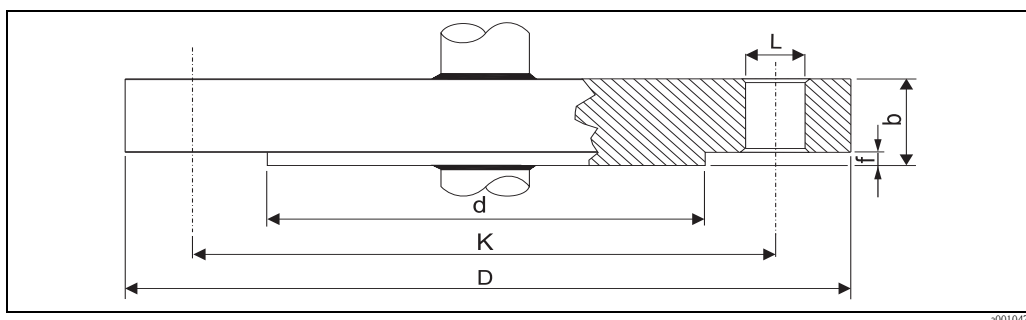

Basic dimensions of the flange process connections

For detailed information on the flange dimensions refer to the following flange standards:

- ANSI/ASME B16.5
- ISO 7005-1
- EN 1092-1
- JIS B 2220 : 2004

The flange material must be the same as of the stem of the thermowell. For this reason, flanges are available both in SS 316L/1.4404 and in SS 316Ti/1.4571. For protection tubes in Hastelloy flanges in basic material 316L/1.4404 and a disc in Hastelloy on the surface in contact with the process media will be used.

For the specification PVDF/PTFE/Tantalum protection tube an additional jacket with a disc on the upper end will be used. The standard surface finish of the coupling side of flanges ranges from 3.2 to 6.4 µm (Ra). Other types of flanges can be supplied on request.

Spare parts

- A thermowell is available as spare part TW13 (see Technical Information in chapter 'Documentation').
- The RTD insert is available as spare part TPR100 (see Technical Information in chapter 'Documentation').

If spare parts are required, refer to the following equation: **Insertion length IL = E + L + 10 mm (0.4 in)**

Spare part	Material-No.
Jacket	TA730-*
Gasket set M24x1.5, aramid+NBR (10 pieces)	60001329

Wiring

Wiring diagrams

Type of sensor connection

Head mounted transmitter TMT18x (single input)

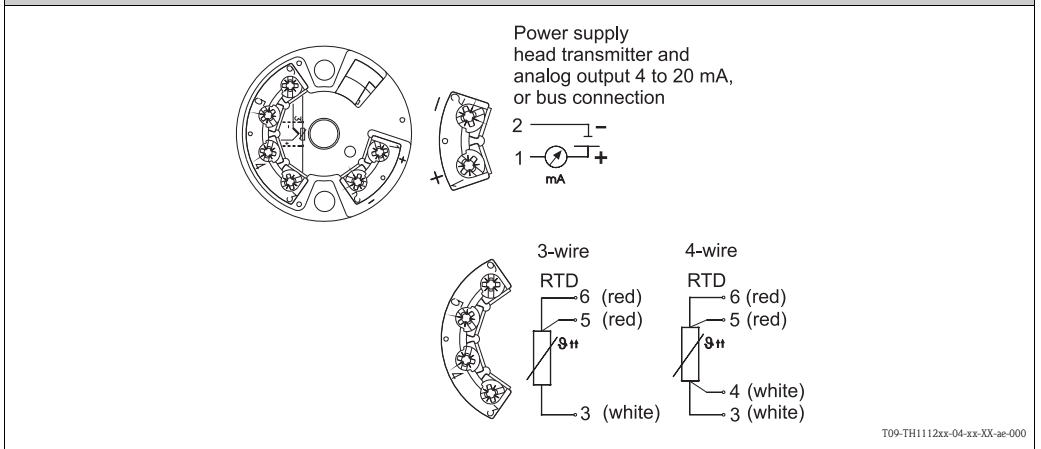

Head mounted transmitter TMT84 and TMT85 (dual input)

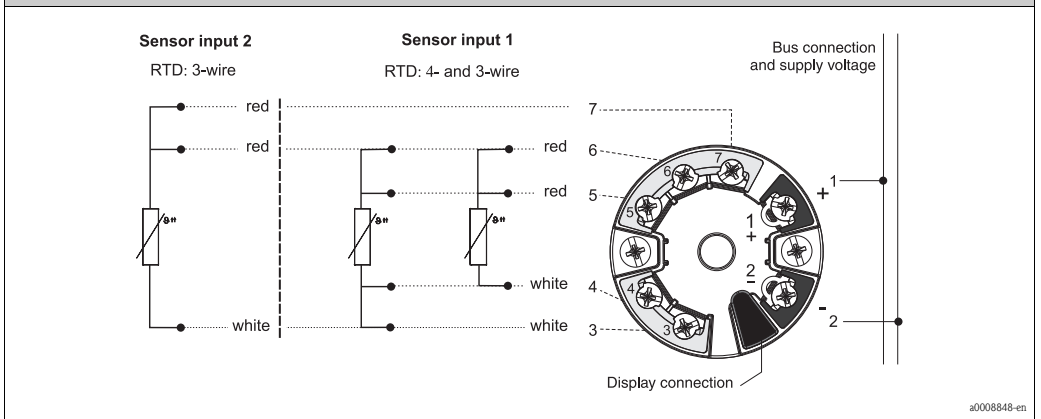

Terminal block mounted

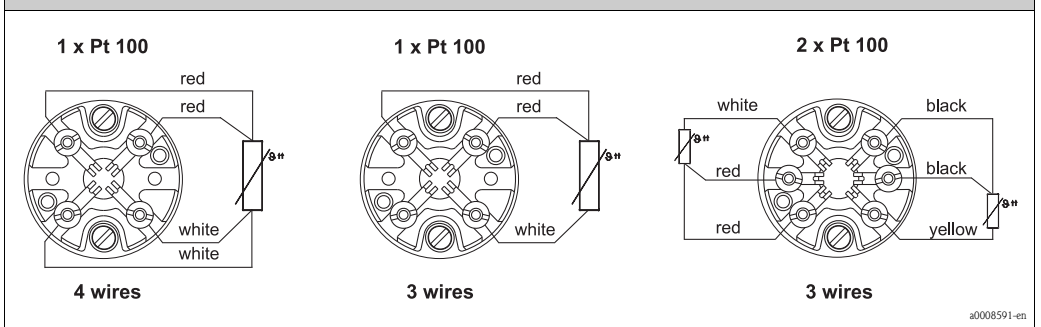

Installation conditions

Orientation

No restrictions.

Installation instructions

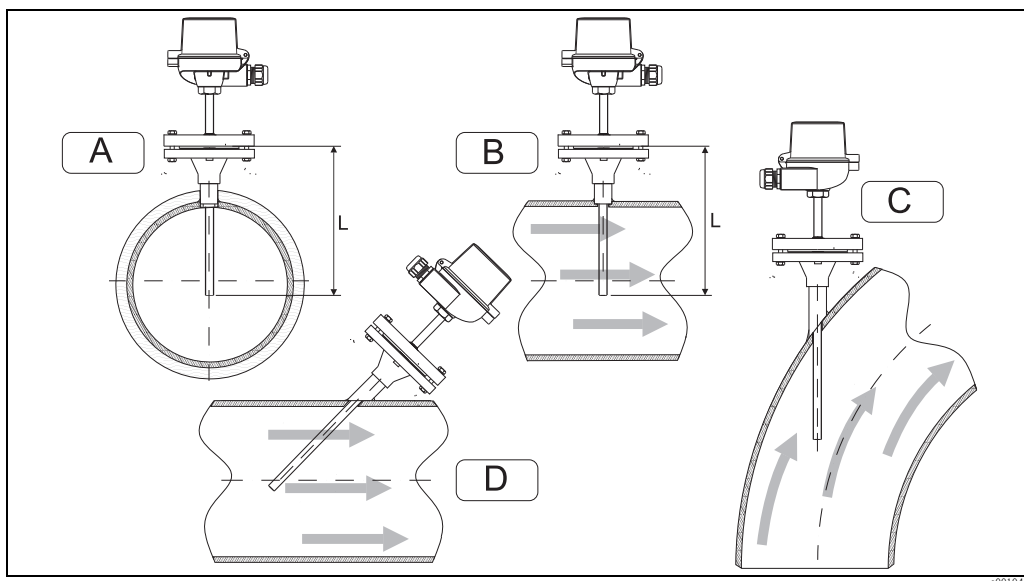

Installation examples

A - B: In pipes with a small cross section the sensor tip should reach or extend slightly past the center line of the pipe (= L).
C - D: Tilted installation.

The immersion length of the thermometer influences the accuracy. If the immersion length is too small then errors in the measurement are caused by heat conduction via the process connection and the container wall. If installing into a pipe then the immersion length must be half of the pipe diameter, ideally.

- Installation possibilities: Pipes, tanks or other plant components
- Minimum immersion length = 80 to 100 mm (3.15 to 3.94 in)
The immersion length should correspond to at least 8 times of the thermowell diameter. Example:
Thermowell diameter 12 mm (0.47 in) x 8 = 96 mm (3.8 in). A standard immersion length of 120 mm (4.72 in) is recommended
- ATEX certification: Always take note of the installation regulations!



Note!

When operating in small nominal bore pipes it must be guaranteed that the thermowell tip is extending far enough into the process to reach out past the pipe center line (see Pos. A and B). A further solution could be an angled (tilted) installation (see Pos. C and D). When determining the immersion length all thermometer parameters and the process to be measured must be taken into account (e.g. flow velocity, process pressure).

Neck tube length

The neck tube is the part between the process connection and the housing. As illustrated in the following figure, the neck tube length may influence the temperature in the terminal head. It is necessary that this temperature is kept within the limit values defined in the chapter "Operating conditions".

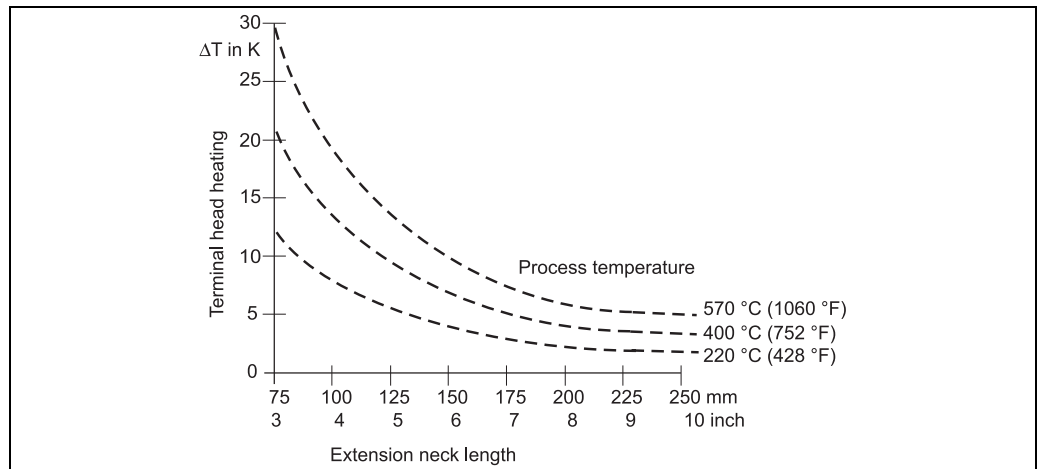

Heating of the terminal head consequent to the process temperature.
 Temperature in terminal head = ambient temperature 20 °C (68 °F) + ΔT

Certificates and approvals

CE Mark

The device meets the legal requirements of the EC directives if applicable. Endress+Hauser confirms that the device has been successfully tested by applying the CE mark.

Hazardous area approvals

For further details on the available Ex versions (ATEX, CSA, FM, etc.), please contact your nearest Endress+Hauser sales organization. All relevant data for hazardous areas can be found in separate Ex documentation. If required, please request copies.

Other standards and guidelines

- IEC 60529:
Degrees of protection by housing (IP-Code).
- IEC 61010-1:
Safety requirements for electrical measurement, control and laboratory instrumentation.
- IEC 60751:
Industrial platinum resistance thermometer
- DIN43772:
Thermowells
- DIN EN 50446, DIN 47229:
Terminal heads
- IEC 61326-1:
Electromagnetic compatibility (EMC requirements)

PED approval

The thermometer complies with paragraph 3.3 of the Pressure Equipment Directive (97/23/CE) and is not marked separately.

Material certification

The material certificate 3.1 (according to standard EN 10204) can be directly selected from the sales structure of the product and refers to the parts of the sensor in contact with the process fluid. Other types of certificates related to materials can be requested separately. The "short form" certificate includes a simplified declaration with no enclosures of documents related to the materials used in the construction of the single sensor and guarantees the traceability of the materials through the identification number of the thermometer. The data related to the origin of the materials can subsequently be requested by the client if necessary.

Test on thermowell

Thermowell pressure tests are carried out in accordance with the specifications in the DIN 43772 standard. With regards to thermowells with tapered or reduced tips that do not comply with this standard these are tested using the pressure of corresponding straight thermowells. Sensors certified for use in Ex Zones, are always tested to pressures according to the same criteria. Tests according to other specifications can be carried out on request. Dye penetration tests verify the absence of cracks on the thermowell welding.

Test report and calibration

The "Factory calibration" is carried out according to an internal procedure in a laboratory of Endress+Hauser accredited by the European Accreditation Organization (EA) to ISO/IEC 17025. A calibration which is performed according to EA guidelines (SIT or DKD calibration) may be requested separately. The calibration is performed on the replaceable insert of the thermometer. In the case of thermometers without a replaceable insert, the entire thermometer - from the process connection to the tip of the thermometer - is calibrated.

Ordering information

Product structure

This information provides an overview of the order options available. The information is not exhaustive, however, and may not be fully up to date. **More detailed** information is available from your local Endress+Hauser representative.

RTD thermometer TR13	
Approval:	
A	Non-hazardous area
B	ATEX II 1 GD EEx ia IIC
E	ATEX II 1/2 GD EEx ia IIC
G	ATEX II 1 G EEx ia IIC
H	ATEX II 3 GD EEx nA II
K	TIIS Ex ia IIC T4
L	TIIS Ex ia IIC T6
Head; Cable Entry:	
B	TA30A Alu, IP66/IP68; M20
C	TA30A Alu, IP66/IP68; NPT 1/2"
D	TA30A Alu, IP66/IP67; M12 plug PA
E	TA21E Alu, screw cap IP65; M12 plug PA
F	TA30A Alu+display, IP66/IP68; M20
G	TA30A Alu+display, IP66/IP68; NPT 1/2"
H	TA30A Alu+display, IP66/IP67; M12 plug PA
J	TA20J 316L, IP66/IP67; M20
K	TA20J 316L, + display, IP66/IP67; M20
L	TA20B, PA, BASF Standard, IP55; M20
M	TA20J 316L, IP66/IP67; M12 plug PA
O	TA30D Alu, high cover, IP66/IP68; M20
P	TA30D Alu, high cover, IP66/IP68; NPT 1/2"
Q	TA30D Alu, IP66/IP67; M12 plug PA
R	TA20R 316L screw cap IP66/IP67; M20
S	TA20R 316L screw cap IP66; M12 plug
T	TA30A Alu, IP66/IP67; 7/8" plug FF
U	TA30A Alu+display, IP66/IP67; 7/8" plug FF
V	TA30D Alu, IP66/IP67; 7/8" plug FF
Z	TA30P PA, high cover, IP65; M20
7	TA20B PA black, IP65; M20
Pipe Diameter; Material:	
A	9 mm; 316L, Ra < 1,6 µm, DIN43772-2F
B	11 mm; 316L, Ra < 1,6 µm, DIN43772-2F
D	9 mm; 316Ti, Ra < 1,6 µm, DIN43772-2F
E	11 mm; 316Ti, Ra < 1,6 µm, DIN43772-2F
F	12 mm; 316Ti, Ra < 1,6 µm, DIN43772-2F/3F
G	9 mm; Hastelloy C276, Ra < 1,6 µm, DIN43772-2F
H	11 mm; Hastelloy C276, Ra < 1,6 µm, DIN43772-2F
L	12 mm; Hastelloy 316Ti, BASF Standard
R	11 mm; stainless steel + 15 mm PTFE
S	12 mm; stainless steel + 16 mm PVDF
T	11 mm; 316Ti + 12 mm Tantal

Neck Length E:	
1	80 mm, DIN43772-2F
2	82 mm, DIN43772-3F
3	145 mm, DIN43772-2F
4	147 mm, DIN43772-3F
8	... mm
9 mm, as specified

Process Connection:	
AB	Flange 1" ANSI 150 RF B16.5; 316L
AD	Flange 1" ANSI 300 RF B16.5; 316L
BA	Flange DN25 PN20 B1 ISO7005-1; 316L
BB	Flange DN25 PN50 B1 ISO7005-1; 316L
EA	Flange DN25 PN40 B1 EN1092-1; 316L
EB	Flange DN40 PN40 B1 EN1092-1; 316L
EC	Flange DN50 PN40 B1 EN1092-1; 316L
FA	Flange DN25 PN40 B1 EN1092-1; 316Ti
FB	Flange DN40 PN40 B1 EN1092-1; 316Ti
FC	Flange DN50 PN40 B1 EN1092-1; 316Ti
FE	Flange DN15, PN40 B1 EN1092-1; 316Ti
FF	Flange DN15, PN40 C EN1092-1; 316Ti
FG	Flange DN25, PN40 C EN1092-1; 316Ti
FH	Flange DN25, PN100 B2 EN1092-1; 316Ti
HA	Flange DN25 PN40 B1 EN1092-1, C276>316L
HC	Flange DN50 PN40 B1 EN1092-1, C276>316L
JA	Flange 5K20 A RF, JIS B 2220, 316L
JB	Flange 10K20 A RF, JIS B 2220, 316L
JC	Flange 5K40 A RF, JIS B 2220, 316L
JD	Flange 10K40 A RF, JIS B 2220, 316L
PA	Flange DN25 PN40 B1 EN1092-1, PVDF>316L
PC	Flange DN50 PN40 B1 EN1092-1, PVDF>316L
TA	Flange DN25 PN40 B1 EN1092-1, PTFE>316L
TC	Flange DN50 PN40 B1 EN1092-1, PTFE>316L
UC	Flange DN25 PN40 B1 EN1092-1, Tantal
UD	Flange DN40 PN40 B1 EN1092-1, Tantal
UE	Flange DN50 PN40 B1 EN1092-1, Tantal

Tip Shape:	
M	Reduced, L ≥ 50 mm
R	Reduced, L ≥ 30 mm
S	Straight, DIN43772-2F
T	Tapered, L ≥ 70 mm
W	Tapered DIN43772-3F, L ≥ 95 mm

Immersion Length L:	
C	120 mm
D	160 mm
E	225 mm
F	250 mm
G	285 mm
H	315 mm
I	935 mm
J	345 mm
K	400 mm
L	465 mm
M	580 mm
N	645 mm
X	... mm, as specified
Y mm, as specified
1	50 mm
2	60 mm
3	70 mm
4	80 mm
5	100 mm

Head Transmitter; Range:	
B	TMT84 PA
C	Terminal block
D	TMT85 FF
F	Flying leads
G	TMT181 (PCP); temp. range to be specified

Documentation

Technical Information:

- RTD Insert for Temperature Sensor Omniset TPR100 (TI268t/02/en)
- Thermowell for temperature sensors Omnigrad M TW13 (TI264t/02/en)
- Temperature head transmitter:
 - iTEMP[®] PCP TMT181 (TI070r/09/en)
 - iTEMP[®] Pt TMT180 (TI088r/09/en)
 - iTEMP[®] HART[®] TMT182 (TI078r/09/en)
 - iTEMP[®] TMT84 PA (TI138r/09/en)
 - iTEMP[®] TMT85 FF (TI134r/09/en)
- Thermowell overheats (TI233t/02/en)
- Flanges (TI432f/00/en)

Hazardous area supplementary documentation:

- Omnigrad TRxx RTD Thermometer ATEX II1GD or II 1/2GD (XA072r/09/a3)
 - Omnigrad TRxx, Omniset TPR100, TET10x, TPC100, TEC10x ATEX II 3GD EEx nA (XA044r/09/a3)
-

Application example

Technical Information:

- Field display RIA261 (TI083r/09/en)
- Active barrier with power supply RN221N (TI073R/09/en)

Instruments International

Endress+Hauser
Instruments International AG
Kaegenstrasse 2
4153 Reinach
Switzerland

Tel. +41 61 715 81 00
Fax +41 61 715 25 00
www.endress.com
info@ii.endress.com

Endress+Hauser 
People for Process Automation
